

Trusted TMR Expander Processor

Product Overview

The Trusted® TMR Expander Processor Module resides in the processor slots of the Trusted Expander Chassis and provides the 'slave' interface between the Expander Bus and the Expander Chassis Backplane. The Expander Bus allows multiple chassis systems to be implemented using Unshielded Twisted Pair (UTP) cable connections whilst maintaining the fault tolerant, high bandwidth Inter-Module Bus (IMB) capabilities.

The Module provides fault containment for the Expander Bus, the Module itself and the Expander Chassis, ensuring that the effects of these potential faults are localised and system availability maximised. The Module is fault tolerant with HIFT TMR architecture. Comprehensive diagnostics, monitoring and testing provide rapid fault identification. Hot-standby and module spare configurations are supported, allowing automatic and manual repair strategies

Features:

- Triple Modular Redundant (TMR), fault tolerant (3-2-0) operation.
- Hardware Implemented Fault Tolerant (HIFT) architecture.
- Dedicated hardware and software test regimes which provide very fast fault recognition and response times.
- Automatic fault handling without nuisance alarming.
- Hot replacement.
- Front Panel indicators that show module health and status.

Page intentionally left blank

PREFACE

In no event will Rockwell Automation be responsible or liable for indirect or consequential damages resulting from the use or application of this equipment. The examples given in this manual are included solely for illustrative purposes. Because of the many variables and requirements related to any particular installation, Rockwell Automation does not assume responsibility or reliability for actual use based on the examples and diagrams.

No patent liability is assumed by Rockwell Automation, with respect to use of information, circuits, equipment, or software described in this manual.

All trademarks are acknowledged.

DISCLAIMER

It is not intended that the information in this publication covers every possible detail about the construction, operation, or maintenance of a control system installation. You should also refer to your own local (or supplied) system safety manual, installation and operator/maintenance manuals.

REVISION AND UPDATING POLICY

This document is based on information available at the time of its publication. The document contents are subject to change from time to time. The latest versions of the manuals are available at the Rockwell Automation Literature Library under "Product Information" information "Critical Process Control & Safety Systems".

TRUSTED RELEASE

This technical manual applies to **Trusted Release: 3.6.1**.

LATEST PRODUCT INFORMATION

For the latest information about this product review the Product Notifications and Technical Notes issued by technical support. Product Notifications and product support are available at the Rockwell Automation Support Centre at

<http://rockwellautomation.custhelp.com>

At the Search Knowledgebase tab select the option "By Product" then scroll down and select the Trusted product.

Some of the Answer ID's in the Knowledge Base require a TechConnect Support Contract. For more information about TechConnect Support Contract Access Level and Features please click on the following link:

https://rockwellautomation.custhelp.com/app/answers/detail/a_id/50871

This will get you to the login page where you must enter your login details.

IMPORTANT A login is required to access the link. If you do not have an account then you can create one using the "Sign Up" link at the top right of the web page.

DOCUMENTATION FEEDBACK

Your comments help us to write better user documentation. If you discover an error, or have a suggestion on how to make this publication better, send your comment to our technical support group at <http://rockwellautomation.custhelp.com>

SCOPE

This manual specifies the maintenance requirements and describes the procedures to assist troubleshooting and maintenance of a Trusted system.

WHO SHOULD USE THIS MANUAL

This manual is for plant maintenance personnel who are experienced in the operation and maintenance of electronic equipment and are trained to work with safety systems.

SYMBOLS

In this manual we will use these notices to tell you about safety considerations.



SHOCK HAZARD: Identifies an electrical shock hazard. If a warning label is fitted, it can be on or inside the equipment.



WARNING: Identifies information about practices or circumstances that can cause an explosion in a hazardous environment, which can cause injury or death, property damage or economic loss.



ATTENTION: Identifies information about practices or circumstances that can cause injury or death.



CAUTION: Identifies information about practices or circumstances that can cause property damage or economic loss.



BURN HAZARD: Identifies where a surface can reach dangerous temperatures. If a warning label is fitted, it can be on or inside the equipment.



This symbol identifies items which must be thought about and put in place when designing and assembling a Trusted controller for use in a Safety Instrumented Function (SIF). It appears extensively in the Trusted Safety Manual.

IMPORTANT

Identifies information that is critical for successful application and understanding of the product.

NOTE

Provides key information about the product or service.

TIP

Tips give helpful information about using or setting up the equipment.

WARNINGS AND CAUTIONS

**WARNING: EXPLOSION RISK**

Do not connect or disconnect equipment while the circuit is live or unless the area is known to be free of ignitable concentrations or equivalent

**AVERTISSEMENT - RISQUE D'EXPLOSION**

Ne pas connecter ou déconnecter l'équipement alors qu'il est sous tension, sauf si l'environnement est exempt de concentrations inflammables ou équivalente

**MAINTENANCE**

Maintenance must be carried out only by qualified personnel. Failure to follow these instructions may result in personal injury.

**CAUTION: RADIO FREQUENCY INTERFERENCE**

Most electronic equipment is influenced by Radio Frequency Interference. Caution should be exercised with regard to the use of portable communications equipment around such equipment. Signs should be posted in the vicinity of the equipment cautioning against the use of portable communications equipment.

**CAUTION:**

The module PCBs contains static sensitive components. Static handling precautions must be observed. **DO NOT** touch exposed connector pins or attempt to dismantle a module.

ISSUE RECORD

Issue	Date	Comments
9	Oct 05	Format
10	Aug 06	Corrections
11	Nov 06	Specifications
12	Dec 06	Cable Distance
13	Sep 15	Rebranded and reformatted
14	Apr 16	Standardisation of Relative Humidity Range and Operating Temperature Statements in the Specification Section
15	Apr 18	New look front panel. Reformatted and updated Specifications table.

Page intentionally left blank

Table of Contents

1.	Description	3
1.1.	Overview	4
1.2.	Power Distribution	4
2.	Installation	5
2.1.	Module Insertion/Removal	6
2.2.	Module Replacement	7
2.3.	Expander Bus Connection	8
2.3.1.	Cable Assembly Replacement	8
2.4.	Expander Chassis IMB Connector (SK1)	9
2.5.	Expander Chassis Bus Connector (PL4)	11
2.6.	Trusted Module Polarisation/Keying	12
3.	Application	15
3.1.	Message Forwarding	15
3.2.	Control Signal Forwarding	15
3.3.	Interface Module Selection	16
3.4.	IMB Power Generation	16
3.5.	IMB Clock Generation	16
3.6.	24 V Supply Monitoring	16
3.7.	Module Information	16
3.8.	Communication Busses	17
3.8.1.	Expander Bus	17
3.8.2.	Inter-Module Bus	17
3.9.	Module Configuration	18
3.10.	I/O Complex Equipment Definition T8310	18
3.11.	Voltage Level Format	20
3.12.	System Initialisation File	20
4.	Operation	21
4.1.	Standby	21
4.2.	Active	21
4.3.	Expander Processor Module Active/Standby Control	21
4.4.	Front Panel	22
4.5.	Module Status LEDs	23
5.	Fault Finding and Maintenance	25
5.1.	Fault Reporting	25

5.2.	Companion Slot.....	25
5.3.	Troubleshooting.....	26
6.	Specifications.....	29

1. Description

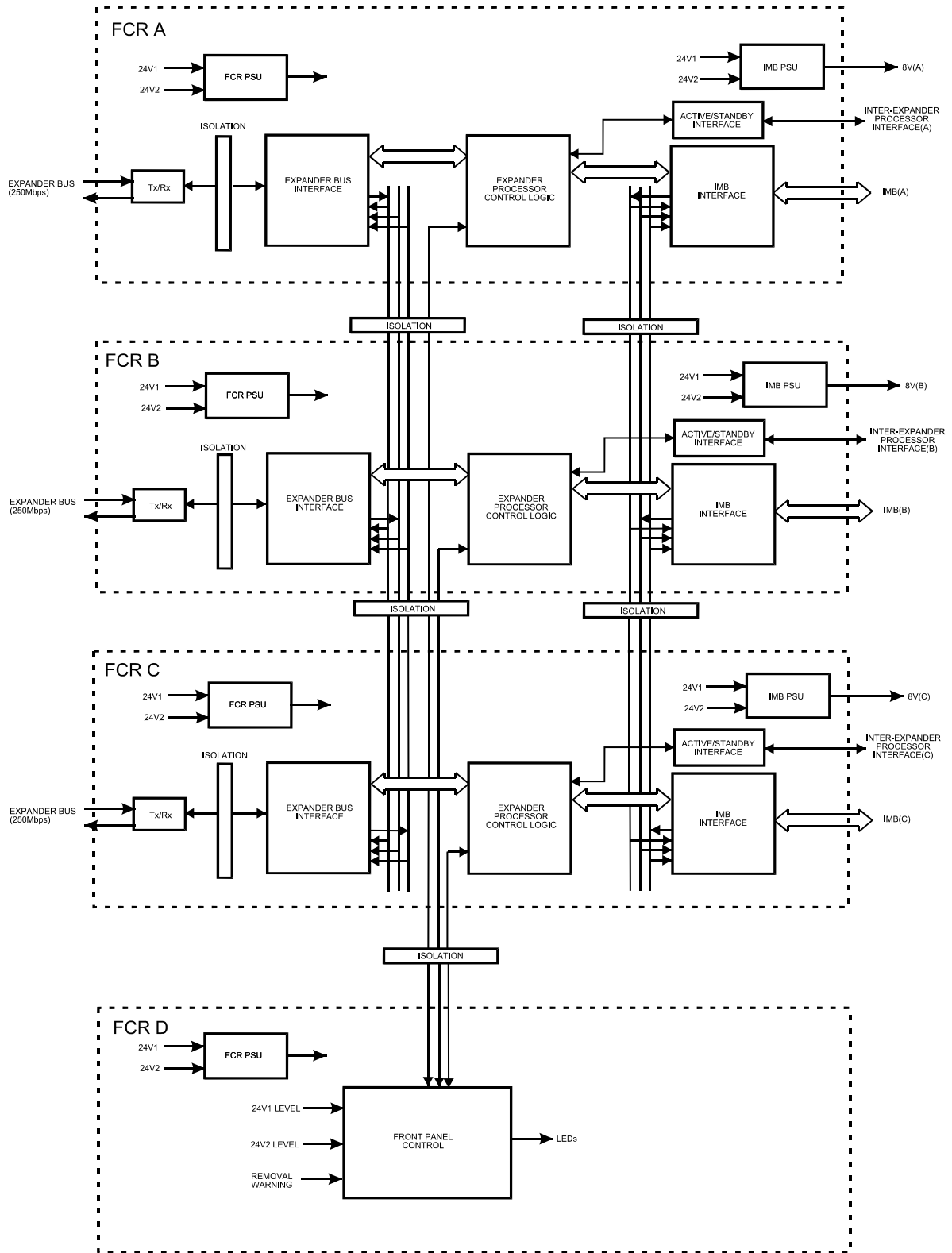

Figure 1 Simplified Block Diagram

1.1. Overview

The TMR Expander Processor is a fault tolerant design based on TMR architecture arranged in a lock-step configuration. Figure 1 shows, in simplified terms, the basic structure of the TMR Expander Processor.

The Module has three main fault containment regions (FCR A, B and C). Each of the main FCRs contains interfaces to the Expander Bus and Inter-Module Bus (IMB), an active/standby interface to the other TMR Expander Processor in the Chassis, control logic, communications transceivers and power supplies.

Communication between the Module and the TMR Processor is via the TMR Expander Interface Module and the triplicated Expander Bus. The Expander Bus is triplicated, point-to-point architecture. Each channel of the Expander Bus comprises separate command and response media. Voting is provided at the Expander Bus Interface to ensure that cable faults are tolerated, and the remainder of the Expander Processor operates in a fully triplicated mode, even in case of cable faults occurring.

Communication between the Module and the I/O Modules in the Expander Chassis is via the IMB on the Backplane of the Expander Chassis. The IMB is identical to that within the Controller Chassis, providing the same fault tolerant, high bandwidth communications between the Interface Modules and the TMR Processor. As with the Expander Bus Interface all transactions are voted, localising faults to the IMB should they occur.

A fourth FCR (FCR D) provides the non-critical monitoring and display functions and is also part of the inter-FCR Byzantine voting structure.

Isolation is provided between FCRs wherever interfaces are required, to ensure that faults cannot propagate between them.

1.2. Power Distribution

The TMR Expander Processor Module derives its internal voltages from dual redundant +24 Vdc power supplied via the module connector from the Trusted Expander Chassis Backplane. Each FCR derives the required supplies independently.

2. Installation



CAUTION:

The Expander Processor Module always resides in one of the two Processor (left most - PL1 and PL2) slots within the Expander Chassis. The Expander Processor must NOT be installed in any other module locations, as this may cause damage to the Module.

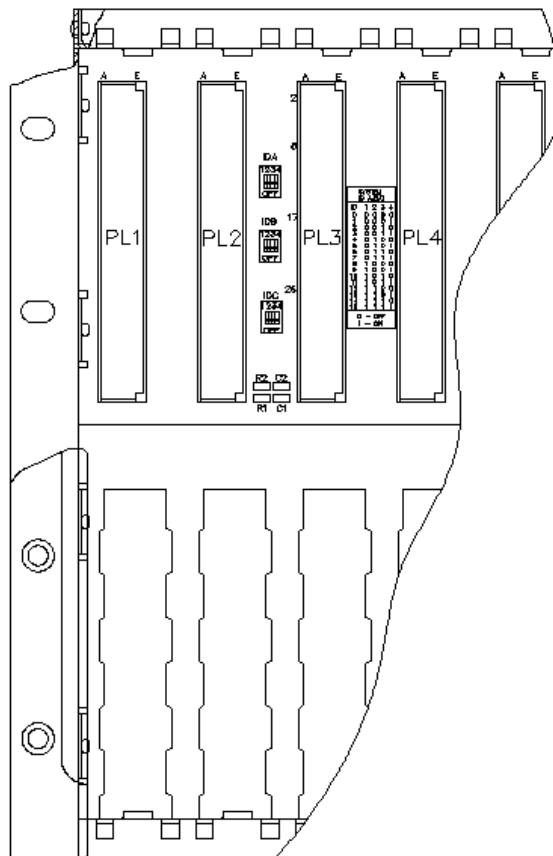

Figure 2 Expander Processor Slots

The two Processor slots must be interconnected using the Cable Hood Assembly shown below.

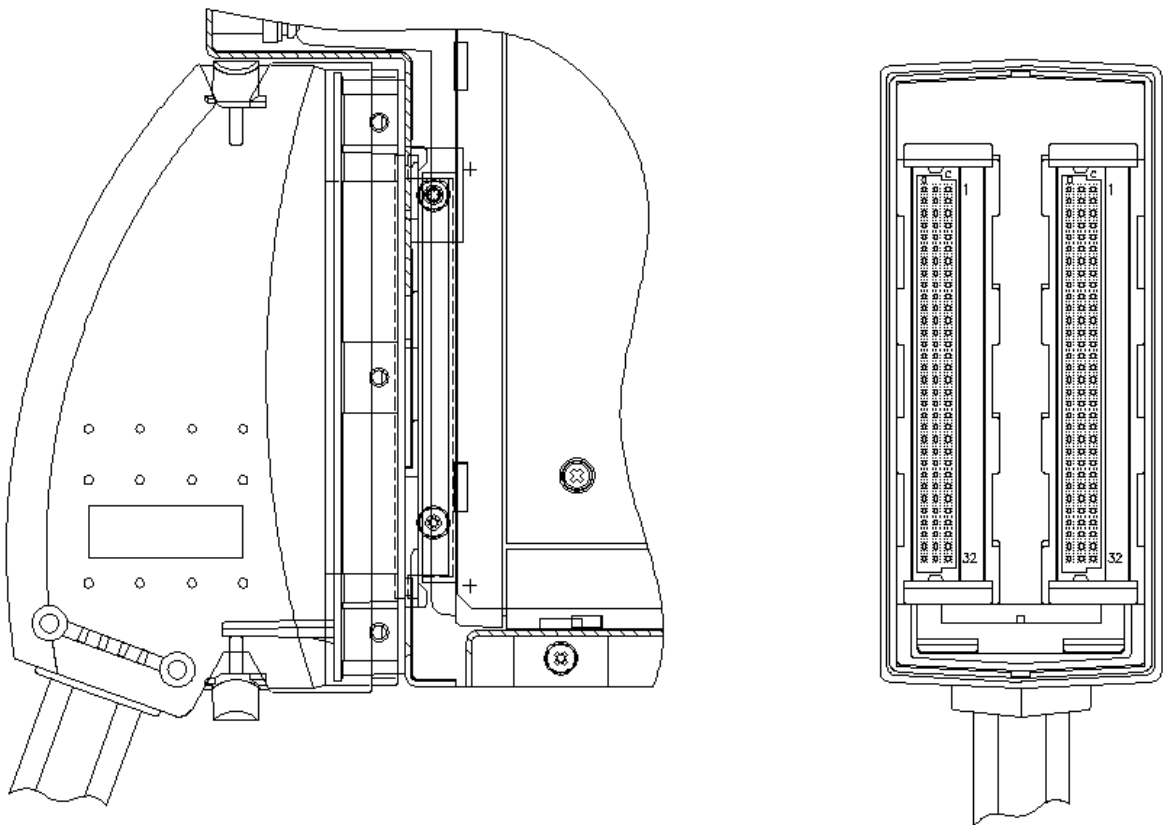

Figure 3 Expander Processor Cable

The Expander Processor Modules are connected to the Expander Interface Modules by the Expander Interface Hot Link Cable TC-301 via the Trusted Expander Interface Adapter Unit T8312.

Remote Expander Processor Modules are connected to the Trusted Fibre Optic Tx/Rx Unit T8314 by the Fibre Tx/Rx Unit to Expander Processor (Remote Expanders) Cable TC-303.

The connection to the Trusted Fibre Optic Tx/Rx Unit from the Expander Interface Modules is via the Trusted Expander Interface Adapter Unit using the Expander Interface Adapter to Fibre Tx/Rx Unit (Remote Expanders) Cable TC-302.

2.1. Module Insertion/Removal



CAUTION:

The module contains static sensitive parts. Static handling precautions must be observed. Specifically ensure that exposed connector pins are not touched. Under no circumstances should the module housing be removed.

Before installation, visually inspect the module for damage. Ensure that the module housing appears undamaged and inspect the I/O connector at the back of the module for bent pins. If the module appears damaged or any pins are bent, do not install the module. Do not try to straighten bent pins. Return the module for replacement.

Ensure that the module is of the correct type.

Record the module type, revision and serial number of the module before installation.

If the module is to reside in a new chassis, or the system is being configured for the first time, ensure that the chassis address has been set correctly before installing the modules. See Expander Chassis Product Description (PD-T8300) for further details.

To install the module:

1. Ensure that the cable assembly is correctly located.
2. Release the ejector tabs on the module using the release key. Ensure that the ejector tabs are fully open.
3. Holding the ejectors, carefully insert the module into the intended slot.
4. Push the module fully home by pressing on the top and bottom of the module fascia.
5. Close the module ejectors, ensuring that they click into their locked position.

2.2. Module Replacement

The replacement module must be inserted in the vacant Processor slot, ensuring that the module is correctly located and the ejector tabs are closed (see Module Insertion and Removal). The newly installed module will perform its power-up sequence.

Ensure that the Light Emitting Diode (LED) indicators on the newly installed module are as follows:

LED 1	Healthy A	Steady Green
LED 2	Healthy B	Steady Green
LED 3	Healthy C	Steady Green

If the original module has reported faults, the TMR Processor may automatically initiate the changeover to the newly installed module. Manual changeover may be initiated either using the ejector tabs on the original module or using commands via the diagnostic interface. To initiate the changeover using the ejector tabs use the following sequence:

1. Release both the top and bottom ejector tabs on the original module using the ejector release tool. DO NOT remove the module.

2. Wait until the original module indicates that it is in the Standby Mode of operation and the newly installed module is in the Active Mode.
3. Remove the original module.

Note: Under no circumstances remove a module that is indicating ACTIVE mode. Removal of an active module may result in modules within the chassis adopting their default (shutdown) state, and initiate shutdown states via the application program.

In Hot-standby configurations, with both Expander Processor Modules installed, the faulted module may be either the active or the standby module. In most cases the system will automatically switch to the healthiest module, therefore only the standby module will require replacement. To replace the active module follow the steps described above. To replace the standby module:

1. Release both the top and bottom ejectors tabs on the standby module using the ejector release tool.
2. Ensure that the other module is indicating the Active Mode of operation.
3. Remove the standby module.

In Hot-standby configurations, the replacement module should then be installed in the position where the previous module was removed. This module will become the standby module.

2.3. Expander Bus Connection

Further details of the Expander Bus cable assembly are provided in the associated Product Description PD-TC300.

2.3.1. Cable Assembly Replacement

It is not intended that the cable should need replacement, however this may be achieved by replacement of the complete cable assembly and requires that the system be shutdown. To remove a cable:

1. Ensure that the correct chassis and slot positions are selected.
2. Ensure the associated chassis slots are not occupied by modules.
3. Press in the hood release button and slide the hood downwards.
4. Remove the hood from the chassis slot by sliding down and rearward.

To insert a new or replacement cable:

1. Ensure that the correct chassis and slot positions are selected.
2. Ensure that the associated chassis slots are not occupied by modules.

3. Present the connector to the chassis backplate slot, taking care to align the lugs of the connector with the cut-outs of the slot.
4. Push the connector hood in and upwards into the slot until the latch engages with the backplate lip.
5. Ensure that the connector hood is secure in its position.

Where it is critical to maintain system operation additional chassis may be installed and on-line operation maintained by transferred control to modules within that chassis using the I/O modules Smart Slot capability.

2.4. Expander Chassis IMB Connector (SK1)

SK1 is a 185-way DIN41642 type connector.

CONNECTOR SK1 PINOUT					
PIN	E	D	C	B	A
2	CHASSIS_GND	CHASSIS_GND	CHASSIS_GND	CHASSIS_GND	CHASSIS_GND
3					
4	IMB_+24V_RTN	IMB_+24V_RTN	IMB_+24V_RTN	IMB_+24V_RTN	IMB_+24V_RTN
5					
6	IMB_+24V_1	IMB_+24V_1	IMB_+24V_1	IMB_+24V_1	IMB_+24V_1
7					
8	IMB_+24V_2	IMB_+24V_2	IMB_+24V_2	IMB_+24V_2	IMB_+24V_2
9					
10	IMBA_CHAS_ID_3	IMBA_CHAS_ID_2	IMBA_CHAS_ID_1	IMBA_CHAS_ID_0	IMBA_MN/IX_ID
11	IMBA_CMDN_RSP	GND	IMBA_XIM_SEL_OUT N	IMBA_XIM_SEL_INN	IMBA_IOM_SELN_1
12	IMBA_D0	GND	IMBA_D1	IMBA_IOM_SELN_2	IMBA_IOM_SELN_3
13	IMBA_D2	GND	IMBA_D3	IMBA_IOM_SELN_4	IMBA_IOM_SELN_5
14	IMBA_D4	GND	IMBA_D5	IMBA_IOM_SELN_6	IMBA_IOM_SELN_7
15	IMBA_D6	GND	IMBA_D7	IMBA_IOM_SELN_8	IMBA_IOM_SELN_9
16	IMBA_CK_OUT	GND	IMBA_XIM_CLK_IN	IMBA_IOM_SELN_10	IMBA_IOM_SELN_11
17	IMBA_IOM_CK1	GND	IMBA_SFTY_WDOG	IMBA_IOM_SELN_12	
18	IMBA_IOM_CK2	GND	IMBA_PWR_FAIL		IMBA_+6.5V
19	IMBB_CHAS_ID_3	IMBB_CHAS_ID_2	IMBB_CHAS_ID_1	IMBB_CHAS_ID_0	IMBB_MN/IX_ID
20	IMBB_CMDN_RSP	GND	IMBB_XIM_SEL OUTN	IMBB_XIM_SEL_INN	IMBB_IOM_SELN_1

CONNECTOR SK1 PINOUT					
PIN	E	D	C	B	A
21	IMBB_D0	GND	IMBB_D1	IMBB_IOM_SELN_2	IMBB_IOM_SELN_3
22	IMBB_D2	GND	IMBB_D3	IMBB_IOM_SELN_4	IMBB_IOM_SELN_5
23	IMBB_D4	GND	IMBB_D5	IMBB_IOM_SELN_6	IMBB_IOM_SELN_7
24	IMBB_D6	GND	IMBB_D7	IMBB_IOM_SELN_8	IMBB_IOM_SELN_9
25	IMBB_CK_OUT	GND	IMBB_XIM_CLK_IN	IMBB_IOM_SELN_10	IMBB_IOM_SELN_11
26	IMBB_IOM_CK1	GND	IMBB_SFTY_WDOG	IMBB_IOM_SELN_12	
27	IMBB_IOM_CK2	GND	IMBB_PWR_FAIL		IMBB_+6.5V
28	IMBC_CHAS_ID_3	IMBC_CHAS_ID_2	IMBC_CHAS_ID_1	IMBC_CHAS_ID_0	IMBC_MN/IX_ID
29	IMBC_CMDN_RSP	GND	IMBC_XIM_SEL_OUT N	IMBC_XIM_SEL_INN	IMBC_IOM_SELN_1
30	IMBC_D0	GND	IMBC_D1	IMBC_XIM_SELN_2	IMBC_IOM_SELN_3
31	IMBC_D2	GND	IMBC_D3	IMBC_XIM_SELN_4	IMBC_IOM_SELN_5
32	IMBC_D4	GND	IMBC_D5	IMBC_XIM_SELN_6	IMBC_IOM_SELN_7
33	IMBC_D6	GND	IMBC_D7	IMBC_XIM_SELN_8	IMBC_IOM_SELN_9
34	IMBC_CK_OUT	GND	IMBC_XIM_CLK_IN	IMBC_XIM_SELN_10	IMBC_IOM_SELN_11
35	IMBC_IOM_CK1	GND	IMBC_SFTY_WDOG	IMBC_IOM_SELN_12	
36	IMBC_IOM_CK2	GND	IMBC_PWR_FAIL		IMBC_+6.5V
37					
38	CHASSIS_GND	CHASSIS_GND	CHASSIS_GND	CHASSIS_GND	CHASSIS_GND

Table 1 IMB SK1 Pin-out Connections

2.5. Expander Chassis Bus Connector (PL4)

PL4 is a 96-way DIN41612, C-type connector.

Pin	CONNECTOR PL4 PINOUT		
	A	B	C
1			TXA+
2			TXA-
3			
4			
5	RXA1+	LB_A_ACTN/STB_OUT	
6	RXA1-	LB_A_ACTN/STB_IN	
7			
8			
9			
10			
11	GND	GND	GND
12			TXB+
13			TXB-
14			
15			
16	RXB1+	LB_B_ACTN/STB_OUT	
17	RXB1-	LB_B_ACTN/STB_IN	
18			
19			
20			
21			

Pin	CONNECTOR PL4 PINOUT		
	A	B	C
22			
23			TXC+
24			TXC-
25			
26			
27	RXC1+	LB_C_ACTN/STB_OUT	
28	RXC1-	LB_C_ACTN/STB_IN	
29			
30			
31			
32			

Table 2 PL4 Pin-out Connections

2.6. Trusted Module Polarisation/Keying

All Trusted Modules have been Keyed to prevent insertion into the wrong position within a chassis. The polarisation comprises two parts: the module and the associated field cable.

Each module type has been keyed during manufacture. The organisation responsible for the integration of the Trusted system must key the cable by removing the keying pieces from the cable so that they correspond with the bungs fitted to the associated module prior to fitting.

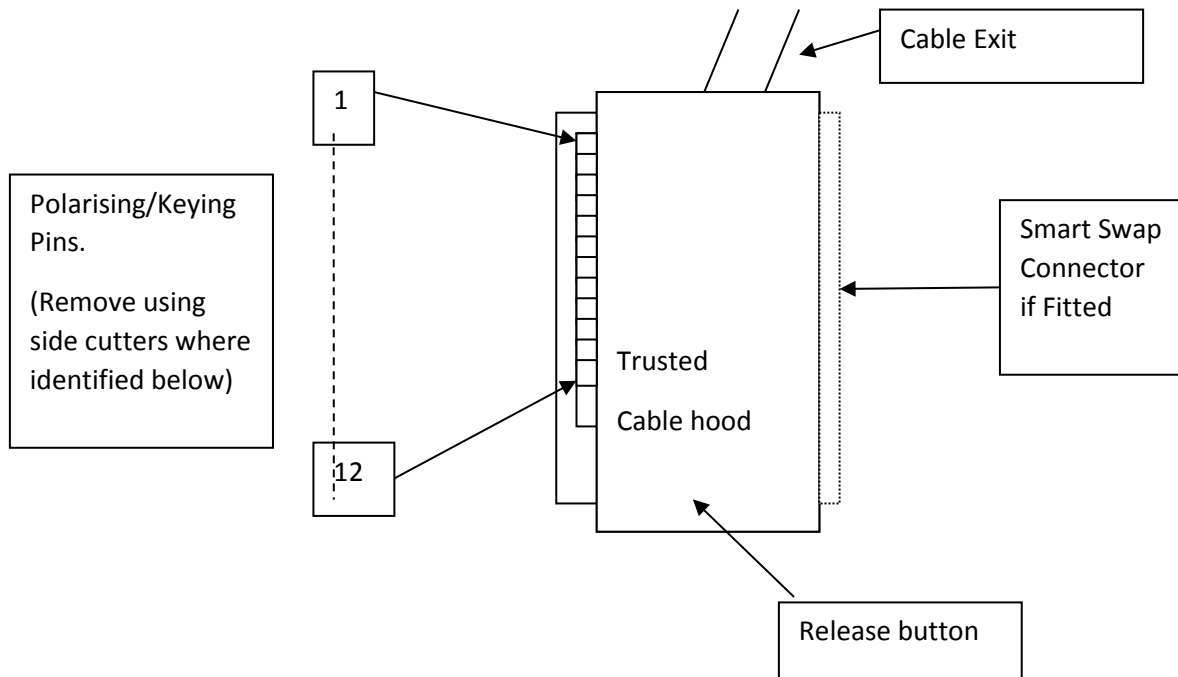

Figure 4 Module Polarisation

For Cables with Companion Slot installations both keying strips must be polarised.

For this Module (T8310) remove keying pins 1, 2 and 5.

Page intentionally left blank

3. Application

3.1. Message Forwarding

The primary function of the Expander is to provide a method of extending the IMB beyond a single Processor Chassis. The active TMR Expander Interface Module receives messages from the Processor Chassis IMB/Backplane and forwards them to the Expander Bus when its slot position is enabled. Similarly, the active TMR Expander Processor Module forwards all messages received from the Expander Bus to the Expander Chassis IMB.

Messages addressed to the Expander Processor Module itself, i.e. those command messages with chassis and slot address fields matching those of the Module, result in the message being handled locally and the appropriate response message being generated. For other command messages the response message received by the active Expander Processor from the addressed module is passed to the Expander Bus and hence to the TMR Expander Interface Module. The active TMR Expander Interface Module then passes the message to the Processor Chassis IMB, subject to the prevailing IMB control signals.

The messages received from the Controller Chassis IMB at the TMR Expander Interface Module are re-synchronised and majority voted before being passed to the triplicated Expander Bus. Similarly, messages received by the TMR Expander Processor Module from the Expander Chassis IMB are re-synchronised and majority voted before onward transmission.

Messages received from the Expander Bus at both the TMR Expander Interface Module and TMR Expander Processor Module are re-synchronised and majority voted (Byzantine voted) before being passed to the associated IMB.

Errors in messages are corrected, and therefore masked using this method. This, however, makes it important that discrepancies in faults in these signals are detected and the information made available for fault reporting purposes to avoid latent fault issues.

3.2. Control Signal Forwarding

The active TMR Expander Interface Module continually monitors and transmits the state of the following signals:

- Power Failure Warning
- System Watchdog
- Command Response Control

All three signals are fully triplicated. These signals are distributed to all of the attached Expander Busses. The TMR Expander Processor Modules forward the received state of these

signals to the Expander Chassis IMB. The direction of these signals is always from TMR Processor to TMR Expander Interface to TMR Expander Processor to Interface (I/O) Module.

As with the message forwarding, these signals are re-synchronised and majority voted, i.e. Byzantine voted at the TMR Expander Interface and TMR Expander Processor Modules. The signals are synchronous within the Expander Chassis even in the case of a fault within the Processor Chassis.

3.3. Interface Module Selection

The active TMR Expander Processor Module monitors the received command messages and decodes chassis and slot information where the message's chassis number matches that set by the local switches.

3.4. IMB Power Generation

The TMR Expander Processor Modules (both active and standby) generate three independent IMB power supplies. These supplies are provided via a diode to the IMB/backplane. These supplies are used to power the triplicated IMB interfaces within the Interface Modules within the Expander Chassis.

These supplies have a common return, commoned with the module's internal 0 V. Failure of any of these supplies will not affect the remaining supplies. Similarly, overload conditions on a supply will not affect the continued operation of the other supplies.

3.5. IMB Clock Generation

The active TMR Expander Processor Module provides synchronised IMB clock signals at the standard IMB rate of 12.5M symbols/second. To minimise clock loading, the IMB connection provides independent signals for odd and even module positions and for the other TMR Expander Processor Module. All of these signals are driven synchronously.

3.6. 24 V Supply Monitoring

The TMR Expander Processor Modules monitor each of the 24 V supplies and generates status information accessible by the TMR Processor.

3.7. Module Information

The following information is recorded by the TMR Expander Processor Module and made available to the TMR Processor.

- Expander Bus link quality, including receive error counts for each communications link and link status.

- Received message error, on a per link/FCR basis, including frame error, checksum error and discrepancy.
- HIFT Clock, master and slave clock status, and master/slave switching.
- FCR watchdog status.
- Current active/standby status.
- IMB status information.
- 24 V supply levels.
- Module type code and serial number.
- Module removed flap status.

3.8. Communication Busses

3.8.1. Expander Bus

Each TMR Expander Processor Module contains a Bus Interface, isolation components and transceivers to the Expander Bus. The triplicated Expander Bus provides communication interconnection between the TMR Processor Chassis and the Expander Chassis at a data transfer rate of 1.5 Gbps via unshielded twisted pair (UTP) cables.

3.8.2. Inter-Module Bus

Each TMR Expander Processor Module FCR contains a Bus Interface to the Inter-Module Bus. The triplicated Inter-Module Bus provides communication interconnection between modules in the TMR Expander Chassis, at a data transfer rate of up to 12.5 Mbps.

The Inter-Module Bus handles the following triplicated signals:

Data	- 8-bit, bi-directional bus.
Control	- Bus clocks, module enables and bus direction control.
System Watchdog	- System Watchdog signal to the I/O Modules.
Power Fail	- System power fail warning to I/O Modules.
Slot	- Indicating the left or right Trusted TMR Expander Processor slot position to the Trusted TMR Processor.
Chassis ID	- a 4-bit code indicating the chassis number or id.

3.9. Module Configuration

The Expander Processor requires no configuration to the Module itself. The Module provides status information that is available to the application programmer. The **IEC 61131 TOOLSET** provides the interface to configure and use this status information.

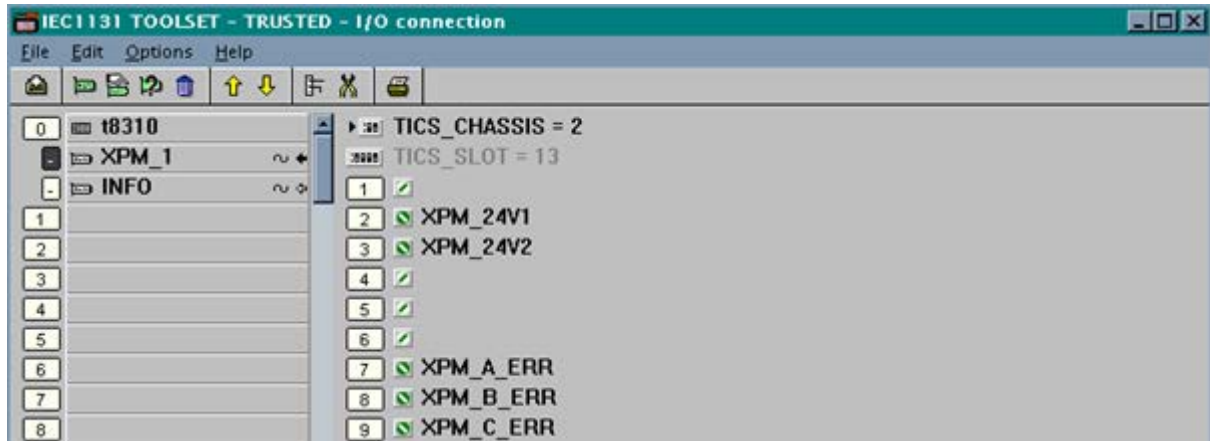

Figure 5 Module Configuration

3.10. I/O Complex Equipment Definition T8310

Each Module fitted in a Trusted System requires an entry in the I/O Connection table, specifying its chassis and slot number. The I/O Complex Equipment Definition allows control of the Module's functions, and provides information on its status. For information on editing the I/O Connection table, refer to PD-T8082. The definition for this Module is described below.

OEM PARAMETERS

OEM parameter	Valid numbers	Description
TICS_CHASSIS	2 – 15	The TICS chassis & slot number where the T8310 module is placed. Expander Processor Modules cannot be placed in a Processor Chassis. By definition, the primary module is placed in the left-hand slot (13) and the secondary in the right-hand slot (14).
TICS_SLOT	13 and 14 (Expander Chassis)	

CONFIGURATION

Physical Module:

RACK 1: [XPM_0]	16 ANALOGUE inputs	Channel 1: Not used Channel 2: 24 Vdc Feed 1 Channel 3: 24 Vdc Feed 2 Channel 4: Not used Channel 5: Not used
-----------------	--------------------	---

		Channel 6: Not used
		Channel 7: Slice A Rx error count
		Channel 8: Slice B Rx error count
		Channel 9: Slice C Rx error count
		Channels 10 to 16 – Not used.
RACK 2: (INFO)	11 INTEGER inputs	Channel 1: Chassis position of AM
		Channel 2: Slot position of AM
		Channel 3: Indication of global health of AM
		1 – No slice errors and module is responding
		0 – Some error has been found
		Channel 4: Current state of AM
		Channel 5: Chassis position of SM
		0 – No partner exists
		Channel 6: Slot position of SM
		0 – No partner exists
		Channel 7: Indication of global health of SM
		1 – No slice errors and module is responding
		0 – Some error has been found
		Channel 8: Current state of SM
		Channel 9: Slice information of SM. See Note
		Channel 10 Is AM the Primary Module
		1 – Yes 0 – Not
		Channel 11: Not used

APPENDIX:

Note:	Bit 0	AM slice A: 1 - Slice is responding and there are no slice errors. 0 - Slice is either NOT responding or there is a slice error.
	Bit 1	AM slice B: 1 - Slice is responding and there are no slice errors. 0 - Slice is either NOT responding or there is a slice error.
	Bit 2	AM slice C: 1 - Slice is responding and there are no slice errors. 0 - Slice is either NOT responding or there is a slice error.
	Bit 3	AM ejectors open: 1 - AM ejectors open. 0 - AM ejectors closed.
	Bit 4	SM slice A: 1 - Slice is responding and there are no slice errors. 0 - Slice is either NOT responding or there is a slice error.
	Bit 5	SM slice B: 1 - Slice is responding and there are no slice errors. 0 - Slice is either NOT responding or there is a slice error.
	Bit 6	SM slice C: 1 - Slice is responding and there are no slice errors. 0 - Slice is either NOT responding or there is a slice error.
	Bit 7	SM ejectors open: 1 – SM ejectors open. 0 - SM ejectors closed.

3.11. Voltage Level Format

The voltage level is reported as an integer, with the units being $\frac{1}{512}V$. This may be used directly, scaled arithmetically or scaled using the conversion tables.

When used directly the value may be considered as a fixed-point binary value, i.e.:

Bit																
15	14	13	12	11	10	9	8	7		6	5	4	3	2	1	0
Sign	Integer								.	Fractional						

To scale the value arithmetically simply divide the returned 'integer' by 512 to return the voltage as either a REAL or INTEGER as required.

The input conversion tables may be used to convert the input value to engineering units, in this case voltage. This is the recommended method where the value is not to be used directly. The full-scale range for this number format is decimal ± 256 , corresponding to physical range -32768 to $+32767$.

3.12. System Initialisation File

There is no System.INI File entry for this Module. The module's existence is assumed for every Expander Chassis defined in the System.INI configuration.

4. Operation

4.1. Standby

Standby is the default mode of operation for the Module, once internal supply levels are established. In this mode the module may receive messages addressed to the Module itself over the IMB or Expander Bus. Response messages over the Expander Bus will only be transmitted following a transition to the Active Mode. The Module does not provide the capability of passing messages to and from other modules within the Expander Chassis in this mode.

4.2. Active

In the Active Mode, the Module is responsible for the forwarding of messages from the Expander Bus to the Expander Chassis IMB, and response messages from the Expander Chassis IMB to the Expander Bus. The Module also provides all of the functions available within the Standby Mode of operation.

4.3. Expander Processor Module Active/Standby Control

TMR Expander Processor Module transition between Active and Standby (and vice-versa) is controlled locally by negotiation between two TMR Expander Processor Modules. Interlocks are incorporated within the TMR Expander Processor Module to ensure that both modules within an Active/Standby configuration cannot assume Active Mode operation.

Where both Modules are healthy, the Active mode of operation defaults to the left-most Module.

4.4. Front Panel

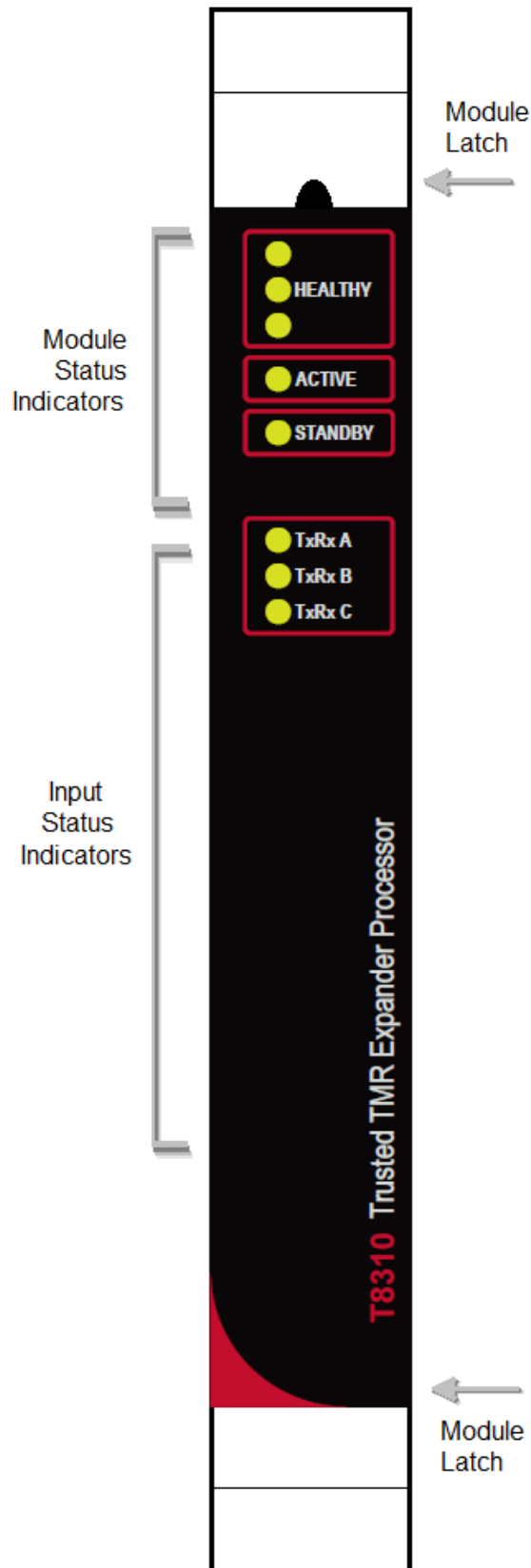

Figure 6 Front Panel

4.5. Module Status LEDs

LED	State	Description
Healthy	On Steady Green	The Module is healthy.
	Flashing Red	Fault on the corresponding Channel.
Active	Green	Module is in the Active state.
Standby	On Steady Green	Module is in the Standby state.
Communications Activity	Off	No activity or failed.
	Green	Receive activity.
	Red	Transmit activity.

Table 3 Module Status Indicators

When the Module is in standby, no Transmit activity (Red LED) will be observed.

Page intentionally left blank

5. Fault Finding and Maintenance

5.1. Fault Reporting

Input Module faults are reported to the user through visual indicators (LEDs) on the front panel of the Module. Faults are also reported via status variables which may be automatically monitored in the application programs, and external system communications interfaces. There are generally two types of faults that must be remedied by the user; external wiring and module faults. External wiring faults require corrective action in the field to repair the fault condition. Module faults require replacement of the Module.

5.2. Companion Slot

The Expander Processor operates in a Companion Slot configuration. Two adjacent slots in a Trusted Chassis are configured for the same module function. One slot is the primary slot and the other a unique secondary (or spare) slot. The two slots are joined at the rear of the Trusted Chassis with a double-width Interface Cable that connects both slots to common IMB connections. During normal operations, the primary slot contains the Active Module as indicated by the Active indicator on the Front Panel of the Module. The secondary slot is available for a spare module that will normally be the Standby Module as indicated by the Standby indicator on the Front Panel of the Module.

Depending on the installation, a hot-spare module may already be installed, or a module blank will be installed in the standby slot. If a hot-spare Module is already installed, transfer to the Standby Module occurs automatically if a module fault is detected in the Active Module. If a hot spare is not installed, the system continues operating from the Active Module until a spare module is installed

5.3. Troubleshooting

Symptom	Possible Cause	Solution
All front panel indicators off	Lack of power	If all other modules within the chassis also show no indicators, check the power distribution and connection to the chassis.
	Front panel interface (FCR D) failure	<p>Check if other modules within the chassis have LEDs illuminated.</p> <p>Check if it is possible to communicate with other modules within the chassis – using either the chassis board type (T8300) or the diagnostic utility. If communications is possible and this is the only Expander Processor installed, the failure is within FCR D and the module should be replaced.</p> <p>If another Expander Processor Module is installed, check its status indication. If the other module is indicating Active Mode, check if communications with the potentially faulty module is possible (again using either the Expander Chassis board or diagnostic utility). If communications is possible, note the information returned as part of the Expander Processor board and then initiate the module replacement.</p>
Single FCR indicator flashing RED	Single main FCR failure.	The module will continue to provide communications between the Expander Bus and the modules within the chassis. However, the module should be replaced as soon as practical.
Multiple FCR indicating flashing RED	Multiple failure.	<p>This condition may be indicated briefly during module power-up, but in other circumstances, this indicates a failure beyond the modules fault tolerant capabilities.</p> <p>If the failed module is not the Active Module, it should be removed immediately. A replacement module should be installed as soon as practical.</p> <p>If the module was the Active Module, the system will attempt to switch to the Standby, if it is installed and if the failures do not occur simultaneously.</p>
Flashing standby indicator	Software detected fault	This indicates that the TMR Processor has detected a fault within the module and has switched to the previously Standby Module. The faulted module should be removed as soon as possible and a replacement installed as soon as practical.
Both active or standby LEDs OFF	LED failure	<p>This condition may be indicated briefly during module power-up.</p> <p>If another Expander Processor Module is installed within the same chassis, use its indicators to verify the Active/Standby Mode of this module. To avoid confusion it is recommended that this module be replaced at some convenient time, initiating the Active/Standby changeover to the other module if necessary.</p>

Symptom	Possible Cause	Solution
All Comms activity LEDs off	Expander Interface Module failure or missing	Check for the presence and healthy state of the Expander Interface Module within the Controller Chassis.
	Expander Bus fault	Check the Expander Bus cable assembly is correctly installed at both the Expansion and Controller Chassis. Check that there are no faults within the Expander Bus cabling, replace any cables found to be defective. Check that the Expander Processor Module is installed in the correct slot.
	TMR Processor fault	If the module is indicating active mode, check that the module is reported as not installed/responding using the diagnostic utility. If reported as not responding then replace the module immediately, otherwise replace the module as soon as practical. If the module is indicating Standby Mode of operation, replace the module as soon as practical.
	Front panel interface (FCR D) failure	Verify that the module is continuing to respond using the chassis board type or the diagnostic utility. Replace the module as soon as practical.
Single activity LED off	Expander Interface Module fault	Verify that there is a fault within the Expander Interface Module (within the Controller Chassis). Replace the faulted module as soon as possible.
	Expander Bus Fault	Check the Expander Bus cable assembly is correctly installed at both the expansion and Controller Chassis. Check that there are no faults within the Expander Bus cabling, replace any cables found to be defective.
	Expander Processor receiver fault	Check the communications receive error counters reported as part of the Expander Processor board. If these are rapidly increasing then initiate the changeover to the Standby Module or replace the module as soon as possible. If the fault is within the Standby Module replace the module as soon as convenient.
	Front panel interface (FCR D) failure	If the module is the current active module, install the spare module (if not already installed) and initiate the changeover to the Standby Module. If the module is in standby mode, replace the module when convenient.
Comms Error counters incrementing	Poor cable condition	Check the Expander Bus cabling for damage and replace as necessary. Ensure that the maximum/minimum cable distances have been met.
	Extreme levels of interference (EMI)	If the condition is permanent then measures should be taken to reduce the levels to which the Expander Bus is exposed. The design provides high levels of immunity; this condition will only occur if the system has not been installed within the defined environmental conditions.

Symptom	Possible Cause	Solution
24V Supply Level	Poor/missing supply	The Expander Processor monitors and reports the 24 V supply levels provided at least one of the supplies is within tolerance. If the reported level is below acceptable levels, verify the supply level to the chassis (using either a digital voltmeter (DVM) or by verifying the level reported by other modules). Correct the supply if necessary.
	Monitoring fault	If the voltage reported by the module differs significantly from the measured voltage, or that reported by other modules, replace the module when convenient.
All other modules within the chassis indicate standby mode.	TMR Processor not running (faulted, or application not started).	Verify the condition of the TMR Processor and start the application as necessary.
	Expander Processor Fault	Verify the Expander Processor is faulty by checking the reported condition within the T8300 chassis board or the diagnostic utility. If the module is shown not to be responding, replace the module immediately.
	Expander Bus Fault	Verify that the fault is not the result of a failed Expander Processor (see above). Check that the Expander Bus is connected correctly at both the Processor and Expander Chassis. Check that the Expander Processor(s) are installed in the correct slot(s).
	Expander Processor not installed.	Ensure a healthy Expander Processor Module is installed in the correct slot.
Minor bus interface unit (BIU) errors counters incrementing	Interface Module Fault	The error counters for a single module will be incrementing. Check the values using the diagnostic utility. If the count exceeds a defined limit, the system will attempt to indicate this fault by setting the corresponding healthy LED on the module to red flashing. Replace the faulty Interface Module.
	Expander Processor Fault	The error counters for all the modules within the corresponding chassis will be incrementing. Check the values using the diagnostic utility. If the count exceeds a defined limit, the system will attempt to indicate this fault by setting the corresponding healthy LED on the module to red flashing. Replace the faulty Expander Processor Module as soon as possible.

6. Specifications

Backplane (IMB) Supply	20 Vdc to 32 Vdc
Field Supply	N/A
Power Dissipation	45 W Backplane Supply
Module Location	T8300 Expander Processor Slot
Isolation	50 V Basic Insulation, Module to Backplane Supply
Fusing	Not User Serviceable
Expander Comms Max Distance	
Using TC-301 copper cable	30 m
Using T8314 Fibre TX/RX Units	10 km
Operating Temperature	0 °C to +60 °C (+32 °F to +140 °F)
Storage Temperature	-25 °C to +70 °C (-13 °F to +158 °F)
Relative Humidity - Operating and Storage	10 % – 95 %, non-condensing
Environmental Specifications	Refer to document 552517
Dimensions	
Height	266 mm (10.5 in)
Width	31 mm (1.2 in)
Depth	303 mm (12.0 in)
Weight	1.33 kg (2.9 lb)